

## 800-mA SYNCHRONOUS STEP-DOWN CONVERTER

 Check for Samples: [TPS62052](#), [TPS62054](#), [TPS62056](#), [TPS62050](#), [TPS62051](#)

### FEATURES

- High-Efficiency Synchronous Step-Down Converter With up to 95% Efficiency
- 12- $\mu$ A Quiescent Current (Typ)
- 2.7-V to 10-V Operating Input Voltage Range
- Adjustable Output Voltage Range From 0.7 V to 6 V
- Fixed Output Voltage Options Available in 1.5 V, 1.8 V, and 3.3 V
- Synchronizable to External Clock Signal up to 1.2 MHz
- High Efficiency Over a Wide Load Current Range in Power-Save Mode
- 100% Maximum Duty Cycle for Lowest Dropout
- Low Noise Operation in Forced Fixed Frequency PWM Operation Mode
- Internal Softstart
- Overtemperature and Overcurrent Protected
- Available in 10-Pin Microsmall Outline Package MSOP

### APPLICATIONS

- Cellular Phones
- Organizers, PDAs, and Handheld PCs
- Low Power DSP Supply
- Digital Cameras and Hard Disks

### DESCRIPTION

The TPS6205x devices are a family of high-efficiency synchronous step-down dc/dc converters ideally suited for systems powered from a 1-cell or 2-cell Li-Ion battery or from a 3-cell to 5-cell NiCd, NiMH, or alkaline battery.

The TPS62050 is a synchronous PWM converter with integrated N-channel and P-channel power MOSFET switches. Synchronous rectification increases efficiency and reduces external component count. To achieve highest efficiency over a wide load current range, the converter enters a power-saving pulse-frequency modulation (PFM) mode at light load currents. Operating frequency is typically 850 kHz, allowing the use of small inductor and capacitor values. The device can be synchronized to an external clock signal in the range of 600 kHz to 1.2 MHz. For low noise operation, the converter can be programmed into forced-fixed frequency in PWM mode. In shutdown mode, the current consumption is reduced to less than 2  $\mu$ A. The TPS6205x is available in the 10-pin (DGS) micro-small outline package (MSOP) and operates over an free air temperature range of  $-40^{\circ}\text{C}$  to  $85^{\circ}\text{C}$ .

### TYPICAL APPLICATION CIRCUIT

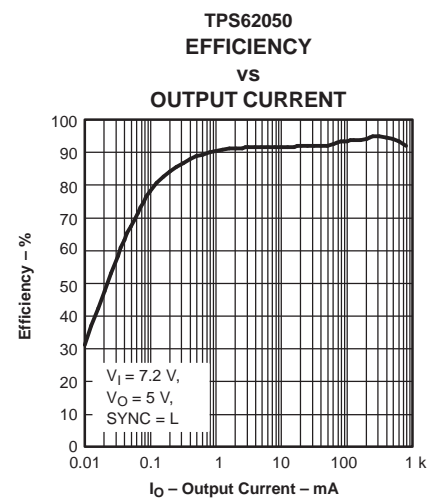
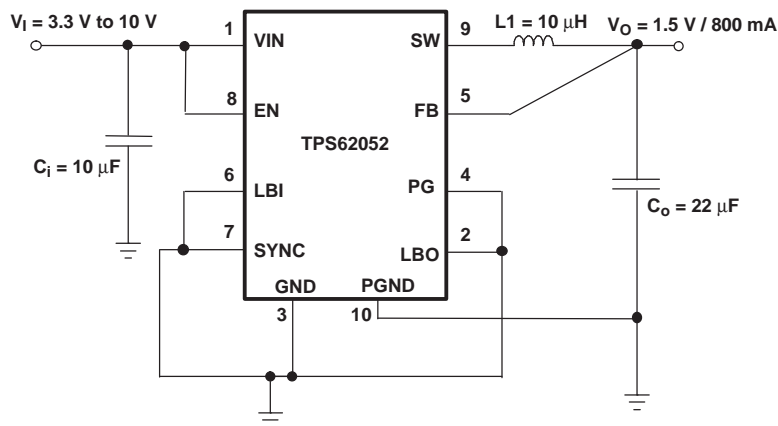

Please be aware that an important notice concerning availability, standard warranty, and use in critical applications of Texas Instruments semiconductor products and disclaimers thereto appears at the end of this data sheet.

MATHCAD is a registered trademark of Mathsoft Incorporated.



This integrated circuit can be damaged by ESD. Texas Instruments recommends that all integrated circuits be handled with appropriate precautions. Failure to observe proper handling and installation procedures can cause damage.

ESD damage can range from subtle performance degradation to complete device failure. Precision integrated circuits may be more susceptible to damage because very small parametric changes could cause the device not to meet its published specifications.

### Package/Ordering Information

PACKAGED DEVICES PLASTIC MSOP <sup>(1)</sup> (DGS)	OUTPUT VOLTAGE	LBI/LBO FUNCTIONALITY	PACKAGE MARKING
TPS62050DGS	Adjustable 0.7 V to 6 V	Standard	BFM
TPS62051DGS	Adjustable 0.7 V to 6 V	Enhanced	BGB
TPS62052DGS	1.5 V	Standard	BGC
TPS62054DGS	1.8 V	Standard	BGE
TPS62056DGS	3.3 V	Standard	BGG

- (1) The DGS packages are available taped and reeled. Add an R suffix to the device type (i.e., TPS62050DGSR) to order quantities of 2500 devices per reel.

### ABSOLUTE MAXIMUM RATINGS

over operating free-air temperature range unless otherwise noted<sup>(1)</sup>

	TPS6205x
Supply voltage, $V_I$	-0.3 V to 11 V
Voltage at EN, SYNC	-0.3 V to $V_I$
Voltage at LBI, FB, LBO, PG	-0.3 V to 7 V
Voltage at SW	-0.3 V to 11 V <sup>(2)</sup>
Output current, $I_O$	850 mA
Maximum junction temperature, $T_J$	150°C
Operating free-air temperature range, $T_A$	-40°C to 85°C
Storage temperature range, $T_{stg}$	-65°C to 150°C
Lead temperature 1,6 mm (1/16 inch) from case for 10 seconds	300°C

- (1) Stresses above these ratings may cause permanent damage. Exposure to absolute maximum conditions for extended periods may degrade device reliability. These are stress ratings only, and functional operation of the device at these or any other conditions beyond those specified is not implied.
- (2) The voltage at the SW pin is sampled in PFM mode 15  $\mu$ s after the PMOS has switched off. During this time the voltage at SW is limited to 7 V maximum. Therefore, the output voltage of the converter is limited to 7 V maximum.

### PACKAGE DISSIPATION RATING

PACKAGE	$T_A \leq 25^\circ\text{C}$ POWER RATING	DERATING FACTOR $T_A \leq 25^\circ\text{C}$	$T_A = 70^\circ\text{C}$ POWER RATING	$T_A = 85^\circ\text{C}$ POWER RATING
10-PIN MSOP <sup>(1)</sup>	555 mW	5.56 mW/°C	305 mW	221 mW

- (1) The thermal resistance junction to ambient soldered onto a PCB of the 10-pin MSOP is 180°C/W.

### RECOMMENDED OPERATING CONDITIONS

	MIN	NOM	MAX	UNIT
Supply voltage at $V_I$	2.7		10	V
Voltage at PG, LBO			6	V
Maximum output current			800 <sup>(1)</sup>	mA
Operating junction temperature	-40		125	°C

- (1) Assuming no thermal limitation

## ELECTRICAL CHARACTERISTICS

 $V_I = 7.2\text{ V}$ ,  $V_O = 3.3\text{ V}$ ,  $I_O = 300\text{ mA}$ ,  $EN = V_I$ ,  $T_A = -40^\circ\text{C}$  to  $85^\circ\text{C}$  (unless otherwise noted)

PARAMETER		TEST CONDITIONS	MIN	TYP	MAX	UNIT
<b>SUPPLY CURRENT</b>						
$V_I$	Input voltage range		2.7		10	V
$I_{(Q)}$	Operating quiescent current	$I_O = 0\text{ mA}$ , SYNC = GND, $V_I = 7.2\text{ V}$		12	20	$\mu\text{A}$
$I_{(SD)}$	Shutdown current	EN = GND		1.5	5	$\mu\text{A}$
		EN = GND, $T_A = 25^\circ\text{C}$		1.5	3	
$I_{(LBI)}$	Quiescent current with enhanced LBI comparator version.	EN = $V_I$ , LBI=GND, TPS62051 only		5		$\mu\text{A}$
<b>ENABLE</b>						
$V_{IH}$	EN high level input voltage		1.3			V
$V_{IL}$	EN low level input voltage				0.3	V
	EN trip point hysteresis			100		mV
$I_{(kg)}$	EN input leakage current	EN = GND or VIN, $V_I = 7.2\text{ V}$		0.01	0.2	$\mu\text{A}$
$I_{(EN)}$	EN input current	$0.6\text{ V} \leq V_{(EN)} \leq 4\text{ V}$		2		$\mu\text{A}$
$V_{(UVLO)}$	Undervoltage lockout threshold			1.6		V
<b>POWER SWITCH</b>						
$r_{DS(on)}$	P-channel MOSFET on-resistance	$V_I \geq 5.4\text{ V}$ ; $I_O = 300\text{ mA}$		400	650	m $\Omega$
		$V_I = 2.7\text{ V}$ ; $I_O = 300\text{ mA}$		600	850	
	P-channel MOSFET leakage current	$V_{DS} = 10\text{ V}$			1	$\mu\text{A}$
	P-channel MOSFET current limit	$V_I = 7.2\text{ V}$ , $V_O = 3.3\text{ V}$	1000	1200	1400	mA
$r_{DS(on)}$	N-channel MOSFET on-resistance	$V_I \geq 5.4\text{ V}$ ; $I_O = 300\text{ mA}$		300	450	m $\Omega$
		$V_I = 2.7\text{ V}$ ; $I_O = 300\text{ mA}$		450	550	
	N-channel MOSFET leakage current	$V_{DS} = 6\text{ V}$			1	$\mu\text{A}$
<b>POWER GOOD OUTPUT, LBI, LBO</b>						
$V_{(PG)}$	Power good trip voltage			$V_{ml} - 2\%$		V
	Power good delay time	$V_O$ ramping positive		50		$\mu\text{s}$
		$V_O$ ramping negative		200		
$V_{OL}$	PG, LBO output low voltage	$V_{(FB)} = 0.8 \times V_O$ nominal, $I_{(sink)} = 1\text{ mA}$			0.3	V
	PG, LBO output leakage current	$V_{(FB)} = V_O$ nominal, $V_{(LBI)} = V_I$		0.01	0.25	$\mu\text{A}$
	Minimum supply voltage for valid power good, LBO signal			2.3		V
$V_{(LBI)}$	Low battery input trip voltage	Input voltage falling		1.21		V
	Low battery input trip point accuracy				1.5%	
$V_{(LBI,HS)}$	Low battery input hysteresis			15		mV
$I_{(kg)(LBI)}$	LBI leakage current			0.01	0.1	$\mu\text{A}$
<b>OSCILLATOR</b>						
$f_S$	Oscillator frequency		600	850	1000	kHz
$f_{(SYNC)}$	Synchronization range		600		1200	kHz
$V_{IH}$	SYNC high level input voltage		1.5			V
$V_{IL}$	SYNC low level input voltage				0.3	V
$I_{(kg)}$	SYNC input leakage current	SYNC = GND or VIN		0.01	0.1	$\mu\text{A}$
	SYNC trip point hysteresis			100		mV
	Duty cycle of external clock signal		20%		90%	
<b>OUTPUT</b>						
$V_O$	Adjustable output voltage range	TPS62050, TPS62051		0.7	6.0	V
$V_{(FB)}$	Feedback voltage	TPS62050, TPS62051		0.5		V
	FB leakage current	TPS62050, TPS62051		0.02	0.1	$\mu\text{A}$
	Feedback voltage tolerance	TPS62050, TPS62051	$V_I = 2.7\text{ V}$ to $10\text{ V}$ , $0\text{ mA} < I_O < 600\text{ mA}$	-3%	3%	

## ELECTRICAL CHARACTERISTICS (continued)

$V_I = 7.2\text{ V}$ ,  $V_O = 3.3\text{ V}$ ,  $I_O = 300\text{ mA}$ ,  $EN = V_I$ ,  $T_A = -40^\circ\text{C}$  to  $85^\circ\text{C}$  (unless otherwise noted)

PARAMETER		TEST CONDITIONS	MIN	TYP	MAX	UNIT
Fixed output voltage tolerance <sup>(1)</sup>	TPS62052	$V_I = 2.7\text{ V}$ to $10\text{ V}$ , $0\text{ mA} < I_O < 600\text{ mA}$	-3%		3%	
	TPS62054	$V_I = 2.7\text{ V}$ to $10\text{ V}$ , $0\text{ mA} < I_O < 600\text{ mA}$	-3%		3%	
	TPS62056	$V_I = 3.75\text{ V}$ to $10\text{ V}$ , $0\text{ mA} < I_O < 600\text{ mA}$	-3%		3%	
Resistance of internal voltage divider for fixed-voltage versions			700	1000	1300	k $\Omega$
Line regulation		$V_O = 3.3\text{ V}$ , $V_I = 5\text{ V}$ to $10\text{ V}$ , $I_O = 600\text{ mA}$		5.2		mV/V
Load regulation		$V_I = 7.2\text{ V}$ ; $I_O = 10\text{ mA}$ to $600\text{ mA}$		0.0045		%/mA
$\eta$	Efficiency	$V_I = 5\text{ V}$ ; $V_O = 3.3\text{ V}$ ; $I_O = 300\text{ mA}$		93%		
		$V_I = 3.6\text{ V}$ ; $V_O = 2.5\text{ V}$ ; $I_O = 200\text{ mA}$		93%		
Duty cycle range for main switches					100%	
Minimum $t_{on}$ time for main switch				100		ns
Shutdown temperature				145		$^\circ\text{C}$
Start-up time		$I_O = 200\text{ mA}$ , $V_I = 5\text{ V}$ , $V_O = 3.3\text{ V}$ , $C_O = 22\text{ }\mu\text{F}$ , $L = 10\text{ }\mu\text{H}$		1		ms

(1) The worst case  $r_{DS(on)}$  of the PMOS in 100% mode for an input voltage of 3.3 V is 0.75  $\Omega$ . This value can be used to determine the minimum input voltage if the output current is less than 600 mA with the TPS62056.

## PIN ASSIGNMENTS

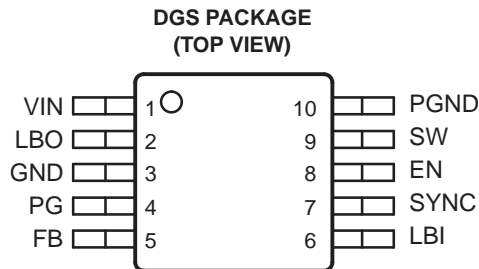

### Pin Functions

PIN NAME	PIN NO.	I/O	DESCRIPTION
EN	8	I	Enable. A logic high enables the converter, logic low forces the device into shutdown mode, reducing the supply current to less than 2 $\mu$ A.
FB	5	I	Feedback pin for the fixed output voltage option. For the adjustable version, an external resistive divider is connected to this pin. The internal voltage divider is disabled for the adjustable version.
GND	3	I	Ground
LBO	2	O	Open drain low battery output. Logic low signal indicates a low battery voltage.
LBI	6	I	Low battery input
PG	4	O	Power good comparator output. This is an open-drain output. A pullup resistor should be connected between PG and VOUT. The output floats when the output voltage is greater than 95% of the nominal value.
PGND	10	I	Power ground. Connect all power grounds to this pin.
SW	9	O	Connect the inductor to this pin. This pin is the switch pin and connected to the drain of the internal power MOSFETS.
SYNC	7	I	Input for synchronization to the external clock signal. This input can be connected to an external clock or pulled to GND or $V_I$ . When an external clock signal is applied, the device synchronizes to this external clock and the device operates in fixed PWM mode. When the pin is pulled to either GND or $V_I$ , the internal oscillator is used and the logic level determines if the device operates in fixed PWM or PWM/PFM mode. SYNC = HIGH: Low-noise mode enabled, fixed frequency PWM operation is forced. SYNC = LOW (GND): Power-save mode enabled, PFM/PWM mode enabled.
VIN	1	I	Supply voltage input

FUNCTIONAL BLOCK DIAGRAM

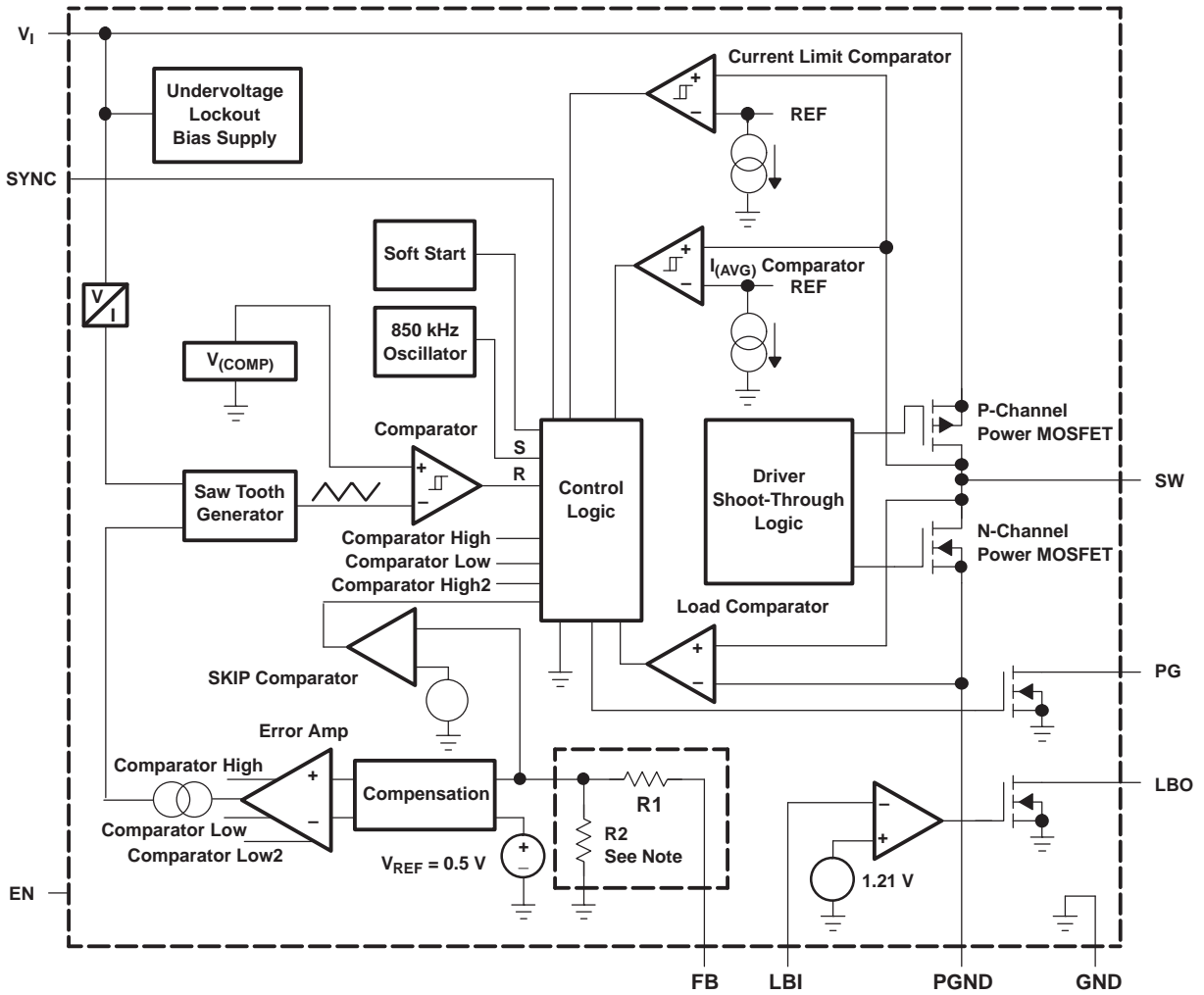

NOTE: For the adjustable versions (TPS62050, TPS62051), the internal feedback driver is disabled and the FB pin is directly connected to the GM amplifier.

## PARAMETER MEASUREMENT INFORMATION

All graphs were generated using the circuit as shown unless otherwise noted. For output voltages other than 5 V, the fixed voltage versions are used. The resistors R1, R2, and the feedforward capacitor (C<sub>ff</sub>) are removed and the feedback pin is directly connected to the output.

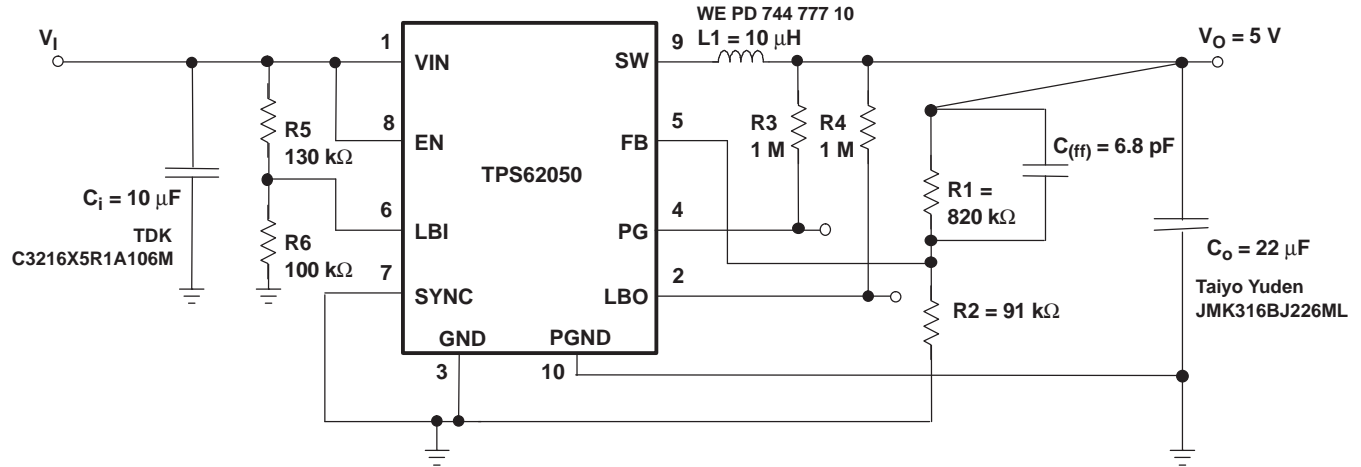

Quiescent Current Measurements and Efficiency Were Taken  
With: R5 = Open, R4 = Open, LBI Connected to GND.

Figure 1. Standard Circuit for Adjustable Version

TYPICAL CHARACTERISTICS

Table 1. TABLE OF GRAPHS

	FIGURE
Efficiency vs load current	1 - 8
Switching frequency vs temperature	9
Output voltage ripple in SKIP mode	10
Output voltage ripple in PWM mode	11
Line transient response in PWM mode	12
Load transient	13
$V_{(switch)}$ and $I_L$ (inductor current) in skip mode	14
Start-up timing	15

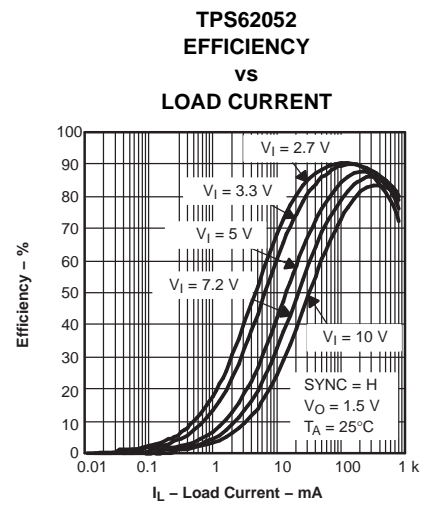
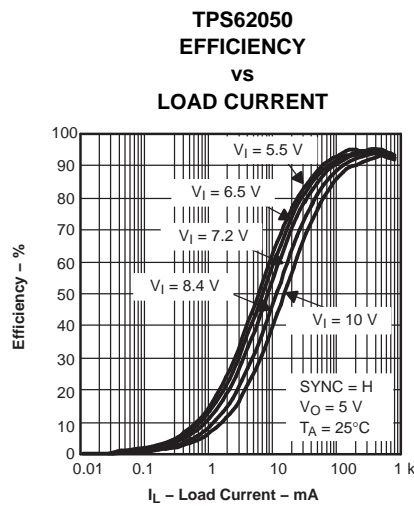
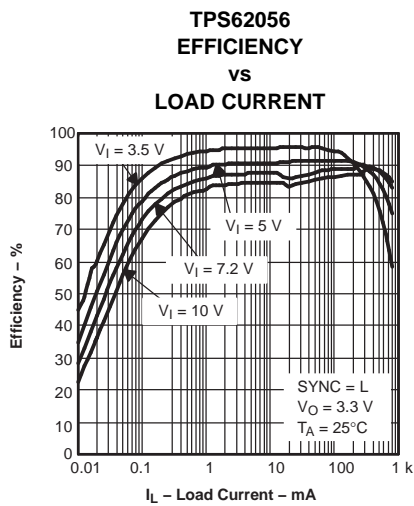
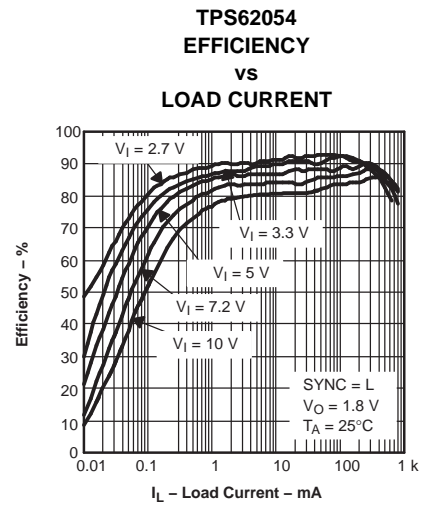
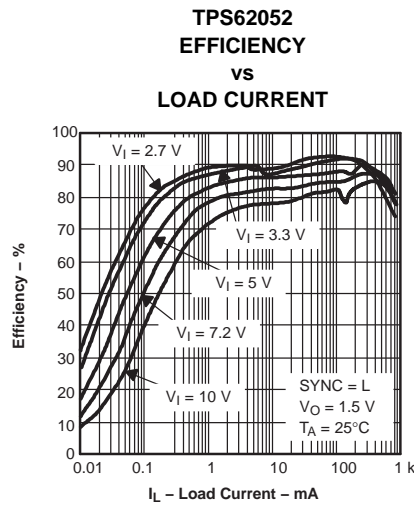
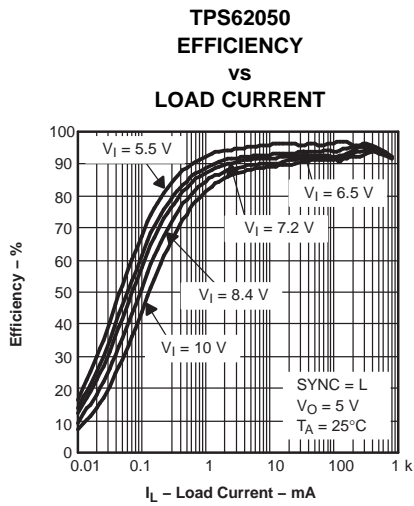



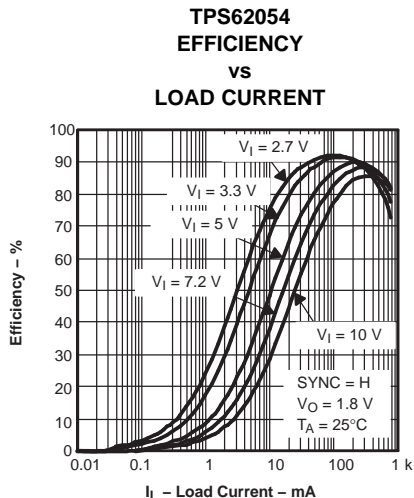

Figure 8.

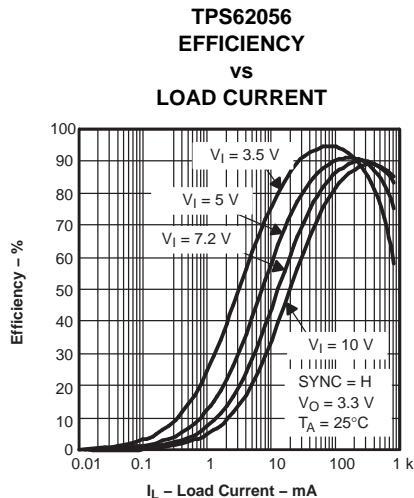

Figure 9.

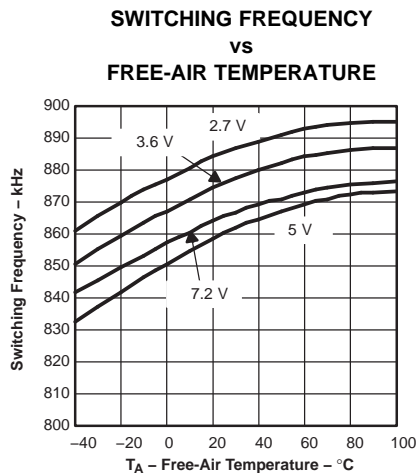

Figure 10.

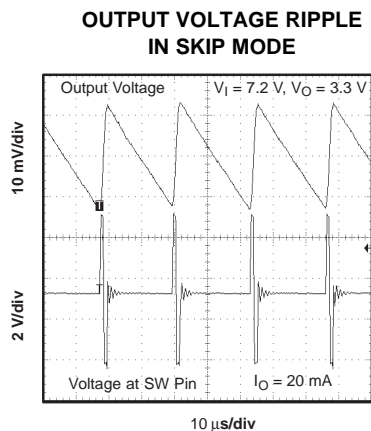

Figure 11.

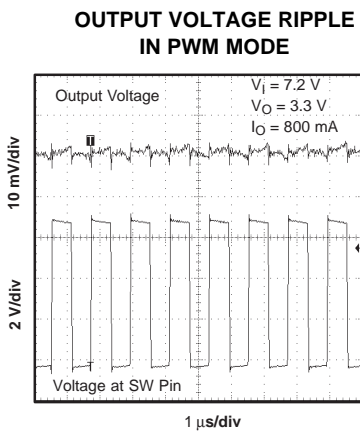

Figure 12.

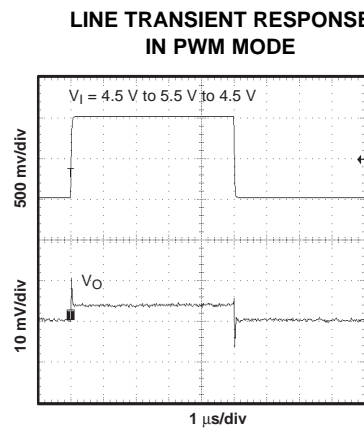

Figure 13.

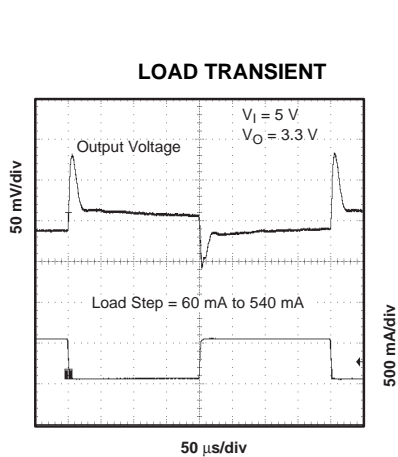

Figure 14.

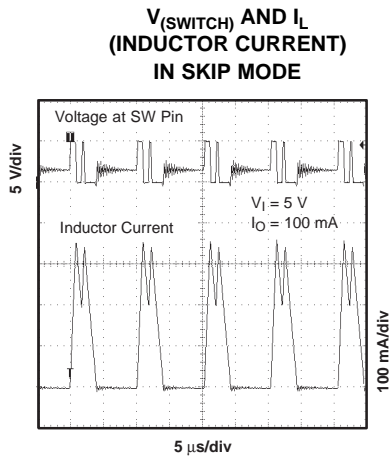

Figure 15.

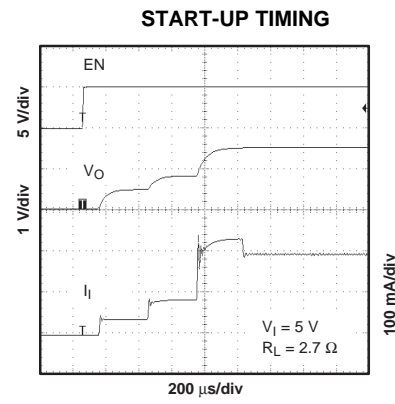

Figure 16.

## APPLICATION INFORMATION

### Operation

The TPS6205x is a synchronous step-down converter that operates with a 850-kHz fixed frequency pulse width modulation (PWM) at moderate to heavy load currents and enters the power-save mode at light load current.

During PWM operation the converter uses a unique fast response voltage mode control scheme with input voltage feed forward to achieve good line and load regulation with the use of small ceramic input and output capacitors. At the beginning of each clock cycle initiated by the clock signal (S), the P-channel MOSFET switch is turned on and the inductor current ramps up until the voltage-comparator trips and the control logic turns the switch off. Also the switch is turned off by the current limit comparator in case the current limit of the P-channel switch is exceeded. After the dead time preventing current shoot through, the N-channel MOSFET rectifier is turned on and the inductor current ramps down. The next cycle is initiated by the clock signal again, turning off the N-channel rectifier and turning on the P-channel switch.

The error amplifier as well as the input voltage determines the rise time of the saw tooth generator; therefore, any change in input voltage or output voltage directly controls the duty cycle of the converter giving a very good line and load transient regulation.

### Constant Frequency Mode Operation (SYNC = HIGH)

In the constant frequency mode, the output voltage is regulated by varying the duty cycle of the PWM signal in the range of 100% to 10%. Connecting the SYNC pin to a voltage greater than 1.5 V forces the converter to operate permanently in the PWM mode even at light or no load currents. The advantage is the converter operates with a fixed switching frequency that allows simple filtering of the switching frequency for noise sensitive applications. In this mode, the efficiency is lower compared to the power-save mode during light loads (see [Figure 17](#)). The N-MOSFET of the devices stays on even when the current into the output drops to zero. This prevents the device from going into discontinuous mode. The device transfers unused energy back to the input. Therefore, there is no ringing at the output that usually occurs in the discontinuous mode. The duty cycle range in constant frequency mode is 100% to 10%.

It is possible to switch from forced PWM mode to the power-save mode during operation by pulling the SYNC pin low. The flexible configuration of the SYNC pin during operation of the device allows efficient power management by adjusting the operation of the TPS6205x to the specific system requirements.

### Power-Save Mode Operation (SYNC = LOW)

As the load current decreases, the converter enters the power-save mode operation. During power-save mode the converter operates with reduced switching frequency in PFM and with a minimum quiescent current to maintain high efficiency. Whenever the average output current goes below the skip threshold, the converter enters the power-save mode. The average current depends on the input voltage. It is 100 mA at low input voltages and up to 200 mA with maximum input voltage. The average output current must be below the threshold for at least 32 clock cycles ( $t_{cy}$ ) to enter the power-save mode. During the power-save mode the output voltage is monitored with a comparator. When the output voltage falls below the comp low threshold set to 0.8% above  $V_O$  nominal, the P-channel switch turns on. The P-channel switch turns off as the peak switch current of typically 200 mA is reached. The N-channel rectifier turns on and the inductor current ramps down. As the inductor current approaches zero, the N-channel rectifier is turned off and the switch is turned on starting the next pulse. When the output voltage can not be reached with a single pulse, the device continues to switch with its normal operating frequency, until the comparator detects the output voltage to be 1.6% above the nominal output voltage. The converter wakes up again when the output voltage falls below the comp low threshold. This control method reduces the quiescent current to typically to 12  $\mu$ A and the switching frequency to a minimum achieving the highest converter efficiency. Having these skip current thresholds 0.8% and 1.6% above the nominal output voltage gives a lower absolute voltage drop during a load transient as anticipated with a standard converter operating in this mode.

### Feedforward Capacitor

The feedforward capacitor,  $C_{(ff)}$  shown in [Figure 21](#), improves the performance in SKIP mode. The comparator is faster, therefore, there is less voltage ripple at the output in SKIP mode. Use the values listed in [Table 2](#). Larger values decrease stability in fixed frequency PWM mode. If the TPS6205x is only operated in fixed frequency PWM mode, the feedforward capacitor is not needed.

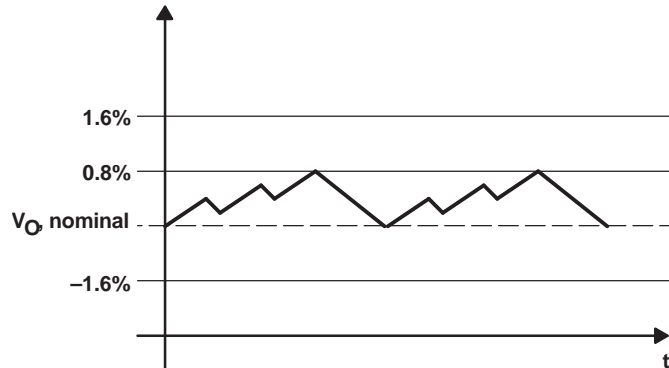

**Figure 17. Power-Save Mode Output Voltage Thresholds**

The converter enters the fixed frequency PWM mode again as soon as the output voltage falls below the comp low 2 threshold set to 1.6% below  $V_{O, \text{nominal}}$ .

### Soft-Start

The TPS6205x has an internal soft-start circuit that limits the inrush current during start-up. This prevents possible voltage drops of the input voltage if a battery or a high impedance power source is connected to the input of the TPS6205x.

The soft-start is implemented as a digital circuit increasing the switch current in steps of 200 mA, 400 mA, 800 mA and then the typical switch current limit of 1.2 A. Therefore the start-up time mainly depends on the output capacitor and load current. Typical start-up time with a 22- $\mu\text{F}$  output capacitor and a 200-mA load current is 1 ms.

### 100% Duty Cycle Low Dropout Operation

The TPS6205x offers the lowest possible input to output voltage difference while still maintaining operation with the use of the 100% duty cycle mode. In this mode, the P-channel switch is constantly turned on. This is particularly useful in battery powered applications to achieve longest operation time by taking full advantage of the whole battery voltage range, i.e. The minimum input voltage to maintain regulation depends on the load current and output voltage and can be calculated as:

$$V_I(\text{min}) = V_O(\text{max}) + I_O(\text{max}) \times (r_{\text{DS(on)}}(\text{max}) + R_L)$$

$I_O(\text{max})$  = Maximum output current plus inductor ripple current

$r_{\text{DS(on)}}(\text{max})$  = Maximum P-Channel switch  $r_{\text{DS(on)}}$

$R_L$  = DC resistance of the inductor

$V_O(\text{max})$  = Nominal output voltage plus maximum output voltage tolerance

### Enable and Overtemperature Protection

Logic low on EN forces the TPS6205x into shutdown. In shutdown, the power switch, drivers, voltage reference, oscillator, and all other functions are turned off. The supply current is reduced to less than 2  $\mu\text{A}$  in the shutdown mode. When the device is in thermal shutdown, the bandgap is forced to stay on even if the device is set into shutdown by pulling EN to GND. As soon as the temperature drops below the threshold, the device automatically starts again.

If an output voltage is present when the device is disabled, which could be an external voltage source or super cap, the reverse leakage current is specified under electrical characteristics. Pulling the enable pin high starts up the TPS6205x with the soft-start as described under the paragraph soft-start. If the EN pin is connected to any voltage other than  $V_I$  or GND, an increased leakage current of typically 10  $\mu\text{A}$  and up to 20  $\mu\text{A}$  can occur.

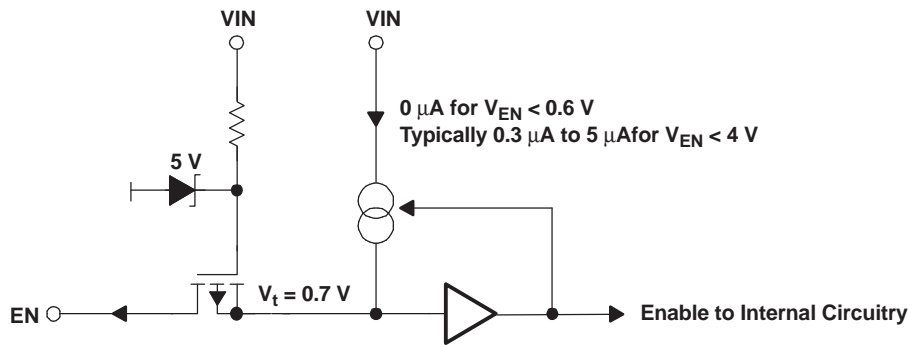

Figure 18. Internal Circuit of the ENABLE Pin

The EN pin can be used in a pushbutton configuration as shown in Figure 19. The external resistor to GND must be capable of sinking  $0.3 \mu\text{A}$  with a minimum voltage drop of  $1.3 \text{ V}$  to keep the system enabled when both switches are open. When the ON-button is pressed, the device is enabled and the current through the external resistor keeps the voltage level high to ensure that the device stays on when the ON-button is released. When the OFF-button is pressed, the device is switched off and the current through the external resistor is zero. The device therefore stays off even when the OFF-button is released.

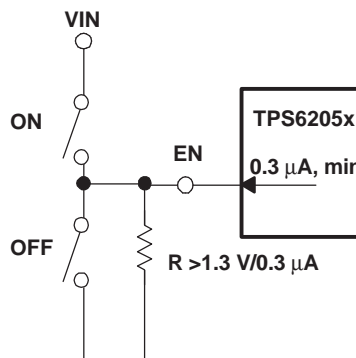

Figure 19. Pushbutton Configuration for the EN-Pin

## Undervoltage Lockout

The undervoltage lockout circuit prevents the device from misoperation at low input voltages. It prevents the converter from turning on the switch or rectifier MOSFET under undefined conditions.

## Synchronization

If no clock signal is applied, the converter operates with a typical switching frequency of  $850 \text{ kHz}$ . It is possible to synchronize the converter to an external clock within a frequency range from  $600 \text{ kHz}$  to  $1200 \text{ kHz}$ . The device automatically detects the rising edge of the first clock and synchronizes to the external clock. If the clock signal is stopped, the converter automatically switches back to the internal clock and continues operation. The switchover is initiated if no rising edge on the SYNC pin is detected for a duration of four clock cycles. Therefore, the maximum delay time can be  $8.3 \mu\text{s}$  if the internal clock has its minimum frequency of  $600 \text{ kHz}$ . During this time, there is no clock signal available. The device stops switching until the internal circuitry is switched to the internal clock source.

When the device is switched between internal synchronization and external synchronization during operation, the output voltage may show transient over/undershoot during switchover. The voltage transients are minimized by using  $850 \text{ kHz}$  as an initial external frequency, and changing the frequency slowly ( $>1 \text{ ms}$ ) to the value desired. The voltage drop at the output when the device is switched from external synchronization to internal synchronization can be reduced by increasing the output capacitor value.

If the device is synchronized to an external clock, the power-save mode is disabled and the device stays in forced PWM mode.

Connecting the SYNC pin to the GND pin enables the power-save mode. The converter operates in the PWM mode at moderate to heavy loads and in the PFM mode during light loads maintaining high efficiency over a wide load current range.

### Power Good Comparator

The power good (PG) comparator has an open drain output capable of sinking typically 1 mA. The PG function is only active when the device is enabled (EN = high). When the device is disabled (EN = low), the PG pin is pulled to GND.

The PG output is only valid after a 250  $\mu$ s delay after the device is enabled and the supply voltage is greater than 2.7 V. Power good is low during the first 250  $\mu$ s after shutdown and in shutdown.

The PG pin floats high when the output voltage exceeds typically 98.5% of its nominal value. Leave the PG pin unconnected, or connect to GND when not used.

### Low-Battery Detector (Standard Version)

The low-battery output (LBO) is an open drain type which goes low when the voltage at the low battery input (LBI) falls below the trip point of 1.21 V  $\pm$ 1.5%. The voltage at which the low-battery warning is issued is adjusted with a resistive divider as shown in Figure 21. The sum of the resistors R1 and R2 is recommended to be in the 100-k $\Omega$  to 1-M $\Omega$  range for high efficiency at low output current. An external pullup resistor at LBO can either be connected to OUT, or any other voltage rail in the voltage range of 0 V to 6 V. During start-up, the LBO output signal is invalid for the first 500  $\mu$ s. LBO is high impedance when the device is disabled. If the low-battery comparator function is not used, connect LBI to ground. The low-battery detector is disabled when the device is disabled. Leave the LBO pin unconnected, or connect to GND when not used.

### ENABLE/Low-Battery Detector (Enhanced Version) TPS62051 Only

The TPS62051 offers an enhanced LBI functionality to provide a precise, user programmable undervoltage shutdown. No additional supply voltage supervisor (SVS) is needed to provide this function.

When the enable (EN) pin is pulled high, only the internal bandgap voltage reference is switched on to provide a reference source for the LBI comparator. As long as the voltage at LBI is less than the LBI trip point, all other internal circuits are shut down, reducing the supply current to 5  $\mu$ A. As soon as input voltage at LBI rises above the LBI trip point of 1.21 V, the device is completely enabled and starts switching.

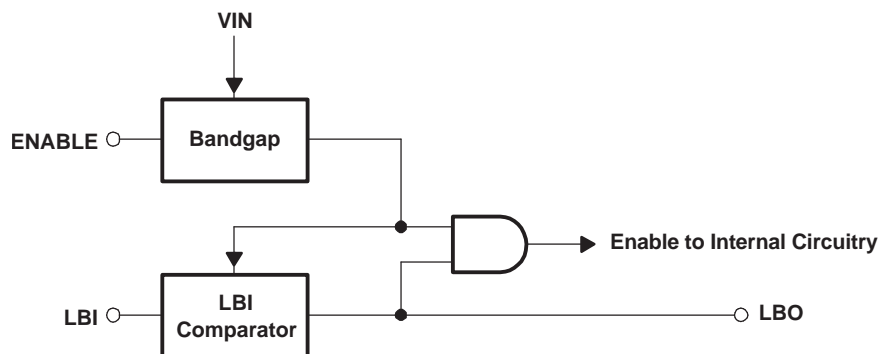

Figure 20. Block Diagram of ENABLE/LBI Functionality for TPS62051

The logic level of the LBO pin is not defined for the first 500  $\mu$ s after EN is pulled high.

When the enhanced LBI is used to supervise the battery voltage and shut down the TPS62051 at low input voltages, the battery voltage rises again when the current drops to zero. The implemented hysteresis on the LBI pin may not be sufficient for all types of batteries. Figure 21 shows how an additional external hysteresis can be implemented.

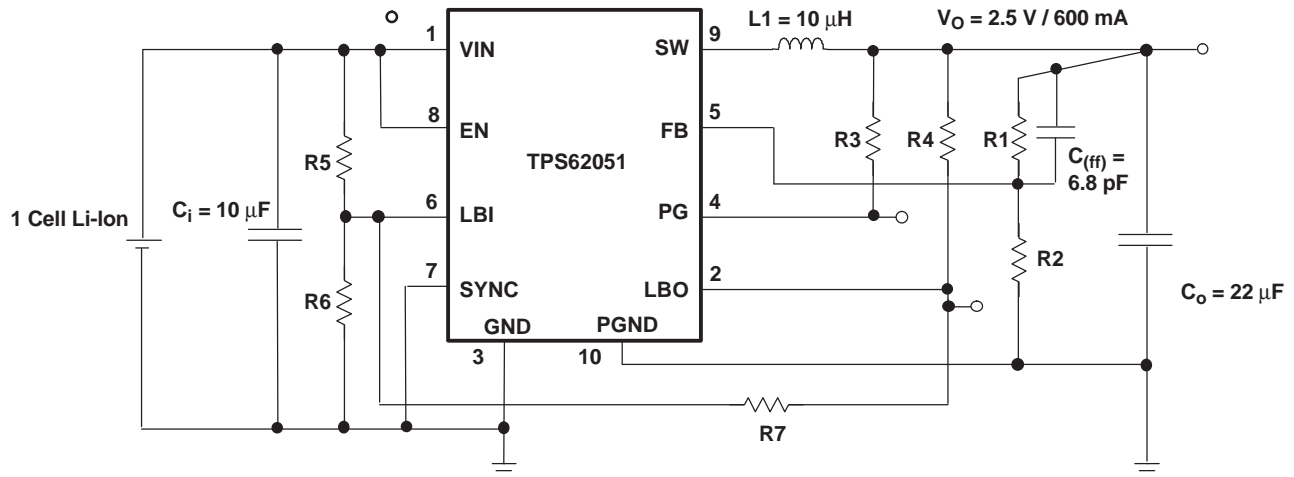

Figure 21. Enhanced LBI With Increased Hysteresis

A MATHCAD® file to calculate R7 can be downloaded from the product folder on the TI web.

### No Load Operation

If the converter operates in the forced PWM mode and there is no load connected to the output, the converter regulates the output voltage by allowing the inductor current to reverse for a short period of time.

### STANDARD CIRCUIT FOR ADJUSTABLE VERSION

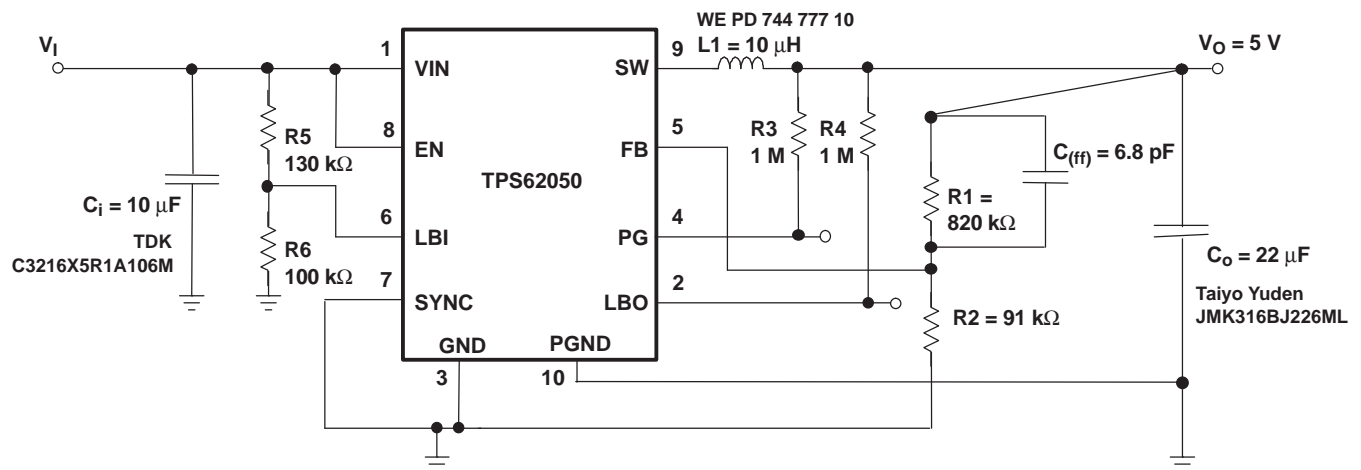

Quiescent Current Measurements and Efficiency Were Taken  
 With: \$R\_5 = \text{Open}\$, \$R\_4 = \text{Open}\$, LBI Connected to GND.

$$V_O = V_{FB} \times \frac{R_1 + R_2}{R_2} \qquad R_1 = R_2 \times \left( \frac{V_O}{V_{FB}} \right) - R_2 \qquad V_{FB} = 0.5\text{V}$$

**Table 2. Values**

NOMINAL OUTPUT VOLTAGE	EQUATION	POSSIBLE RESISTOR COMBINATION	TYPICAL FEEDBACK CAPACITOR
0.7 V	$R1 = 0.4 \times R2$	$R1 = 270 \text{ k}, R2 = 680 \text{ k}$	$C_{(ff)} = 22 \text{ pF}$
1.2 V	$R1 = 1.4 \times R2$	$R1 = 510 \text{ k}, R2 = 360 \text{ k} (1.21 \text{ V})$	$C_{(ff)} = 6.8 \text{ pF}$
1.5 V	$R1 = 2 \times R2$	$R1 = 300 \text{ k}, R2 = 150 \text{ k} (1.50 \text{ V})$	$C_{(ff)} = 6.8 \text{ pF}$
1.8 V	$R1 = 2.6 \times R2$	$R1 = 390 \text{ k}, R2 = 150 \text{ k} (1.80 \text{ V})$	$C_{(ff)} = 6.8 \text{ pF}$
2.5 V	$R1 = 4 \times R2$	$R1 = 680 \text{ k}, R2 = 169 \text{ k} (2.51 \text{ V})$	$C_{(ff)} = 6.8 \text{ pF}$
3.3 V	$R1 = 5.6 \times R2$	$R1 = 560 \text{ k}, R2 = 100 \text{ k} (3.30 \text{ V})$	$C_{(ff)} = 6.8 \text{ pF}$
5 V	$R1 = 9 \times R2$	$R1 = 820 \text{ k}, R2 = 91 \text{ k} (5.0 \text{ V})$	$C_{(ff)} = 6.8 \text{ pF}$

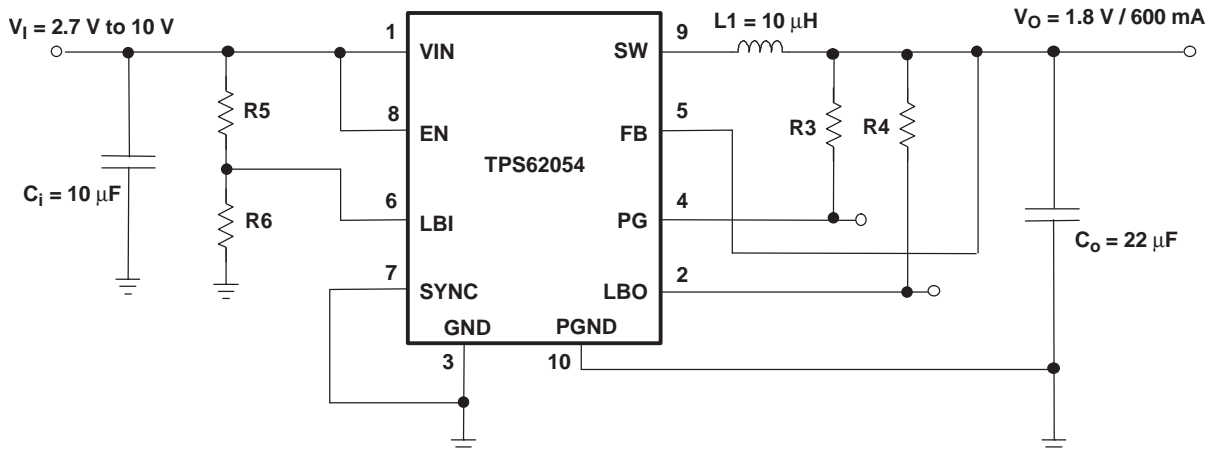
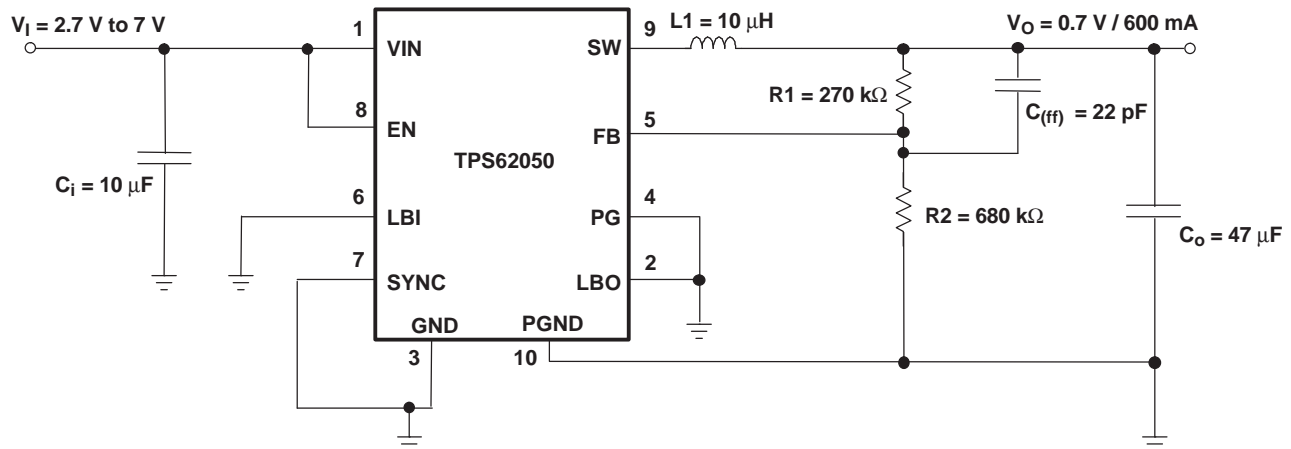
**STANDARD CIRCUIT FOR FIXED VOLTAGE VERSION**

**CONVERTER FOR 0.7-V OUTPUT VOLTAGE**

The TPS62050 is used to generate output voltages as low as 0.7 V. With such low output voltages, the inductor discharges very slowly. This leads to a high output voltage ripple in power-save mode (SYNC = GND). It is therefore recommended to use a larger output capacitor to keep the output ripple low. With an output capacitor of 47 µF, the output voltage ripple is less than 40 mV<sub>pp</sub>.

## LAYOUT AND BOARD SPACE

All capacitors should be soldered as close as possible to the IC.

For information on the PCB layout see the user's guide SLVU081.

Keep the feedback track as short as possible. Any coupling to the FB pin may cause additional output voltage ripple.

## INDUCTOR SELECTION

A 10- $\mu$ H minimum inductor should be used with the TPS6205x. Values larger than 22  $\mu$ H or smaller than 10  $\mu$ H may cause stability problems due to the internal compensation of the regulator. After choosing the inductor value of typically 10  $\mu$ H, two additional inductor parameters should be considered: the current rating of the inductor and the dc resistance. The dc resistance of the inductance directly influences the efficiency of the converter. Therefore, an inductor with lowest dc resistance should be selected for highest efficiency. In order to avoid saturation of the inductor, the inductor should be rated at least for the maximum output current plus half the inductor ripple current which is calculated as:

$$\Delta I_L = V_O \times \frac{1 - \frac{V_O}{V_I}}{L \times f} \quad I_L(\text{max}) = I_O(\text{max}) + \frac{\Delta I_L}{2}$$

f = Switching frequency (850 kHz typical)

L = Inductor value

$\Delta I_L$  = Peak-to-peak inductor ripple current

$I_L(\text{max})$  = Maximum inductor current

The highest inductor current occurs at maximum VIN. A more conservative approach is to select the inductor current rating just for the maximum switch current of the TPS6205x which is 1.4 A maximum. See [Table 3](#) for inductors that have been tested for operation with the TPS6205x.

**Table 3. Inductors**

MANUFACTURER	TYPE	INDUCTANCE	DC RESISTANCE	SATURATION CURRENT
TDK	SLF7032T-	10 $\mu$ H $\pm$ 20%	53 m $\Omega$ $\pm$ 20%	1.4 A
	100M1R4SLF7032T-	22 $\mu$ H $\pm$ 20%	110 m $\Omega$ $\pm$ 20%	0.96 A
	220M96SLF7045T-	10 $\mu$ H $\pm$ 20%	36 m $\Omega$ $\pm$ 20%	1.3 A
	100M1R3SLF7045T- 100MR90	22 $\mu$ H $\pm$ 20%	61 m $\Omega$ $\pm$ 20%	0.9 A
Sumida	CDR74B	10 $\mu$ H	70 m $\Omega$	1.65 A
	CDR74B	22 $\mu$ H	130 m $\Omega$	1.12 A
	CDH74	10 $\mu$ H	49 m $\Omega$	1.8 A
	CDH74	22 $\mu$ H	110 m $\Omega$	1.23 A
	CDR63B	10 $\mu$ H	140 m $\Omega$	1 A
	CDRH4D28	10 $\mu$ H	128 m $\Omega$	1 A
	CDRH5D28	10 $\mu$ H	48 m $\Omega$	1.3 A
Coilcraft	DT3316P-153	15 $\mu$ H	60 m $\Omega$	1.8 A
	DT3316P-223	22 $\mu$ H	84 m $\Omega$	1.5 A
Wuerth	WE-PD 744 778 10	10 $\mu$ H	72 m $\Omega$	1.68 A
	WE-PD 744 777 10	10 $\mu$ H	49 m $\Omega$	1.84 A
	WE-PD 744 778 122	22 $\mu$ H	190 m $\Omega$	1.07A
	WE-PD 744 777 122	22 $\mu$ H	110 m $\Omega$	1.23 A



## OUTPUT CAPACITOR SELECTION

The output capacitor should have a minimum value of 22µF. For best performance, a low ESR ceramic output capacitor is needed.

For completeness, the RMS ripple current is calculated as:

$$I_{RMS(CO)} = V_O \times \frac{1 - \frac{V_O}{V_I}}{L \times f} \times \frac{1}{2 \times \sqrt{3}}$$

The overall output ripple voltage is the sum of the voltage spike caused by the output capacitor ESR plus the voltage ripple caused by charge and discharging the output capacitor:

$$\Delta V_O = V_O \times \frac{1 - \frac{V_O}{V_I}}{L \times f} \times \left( \frac{1}{8 \times C_O \times f} + R_{ESR} \right)$$

The highest output voltage ripple occurs at the highest input voltage  $V_I$ .

## INPUT CAPACITOR SELECTION

Because the buck converter has a pulsating input current, a low ESR input capacitor is required for best input voltage filtering and minimizing the interference with other circuits caused by high input voltage spikes. The input capacitor should have a minimum value of 10 µF and can be increased without any limit for better input voltage filtering. The input capacitor should be rated for the maximum input ripple current calculated as:

$$I_{RMS} = I_{O(max)} \times \sqrt{\frac{V_O}{V_I} \times \left( 1 - \frac{V_O}{V_I} \right)}$$

The worst case RMS ripple current occurs at  $D = 0.5$  and is calculated as:  $I_{RMS} = I_O/2$ . Ceramic capacitors have a good performance because of their low ESR value and they are less sensitive to voltage transients compared to tantalum capacitors. Place the input capacitor as close as possible to the input pin of the IC for best performance.

**Table 4. Capacitors**

MANUFACTURER	PART NUMBER	SIZE	VOLTAGE	CAPACITANCE	TYPE
Taiyo Yuden	JMK212BJ106MG	0805	6.3 V	10 µF	Ceramic
	JMK316BJ106ML	1206	6.3 V	10 µF	Ceramic
	JMK316BJ226ML	1206	6.3 V	22 µF	Ceramic
	LMK316BJ475ML	1206	10 V	4.7 µF <sup>(1)</sup>	Ceramic
	EMK316BJ475ML	1206	16 V	4.7 µF <sup>(1)</sup>	Ceramic
	EMK325BJ106KN-T	1210	16 V	10 µF	Ceramic
Kemet	C1206C106M9PAC	1206	6.3 V	10 µF	Ceramic
TDK	C2012X5R0J106M	0805	6.3 V	10 µF	Ceramic
	C3216X5R0J226M	1206	6.3 V	22 µF	Ceramic
	C3216X5R1A106M	1206	10 V	10 µF	Ceramic

(1) Connect two in parallel.

**Table 5. Capacitor Manufacturers**

MANUFACTURER	CAPACITOR TYPE	INTERNET
Taiyo Yuden	X7R/X5R ceramic	<a href="http://www.t-yuden.com">www.t-yuden.com</a>
TDK	X7R/X5R ceramic	<a href="http://www.component.tdk.com">www.component.tdk.com</a>
Vishay	X7R/X5R ceramic	<a href="http://www.vishay.com">www.vishay.com</a>
Kemet	X7R/X5R ceramic	<a href="http://www.kemet.com">www.kemet.com</a>

## REVISION HISTORY

Note: Page numbers of current version may differ from previous versions.

<b>Changes from Revision D (October 2003) to Revision E</b>	<b>Page</b>
• Changed to Revision E, June 2011 .....	1
• Changed formatting. ....	1
• Changed "goes active high" to "floats" in Terminal Functions table, row PG, description. ....	5
• Changed "becomes active" to "floats" in last paragraph of Power Good Comparator section. ....	13

**PACKAGING INFORMATION**

Orderable Device	Status <sup>(1)</sup>	Package Type	Package Drawing	Pins	Package Qty	Eco Plan <sup>(2)</sup>	Lead/ Ball Finish	MSL Peak Temp <sup>(3)</sup>	Samples (Requires Login)
TPS62050DGS	ACTIVE	MSOP	DGS	10	80	Green (RoHS & no Sb/Br)	CU NIPDAUAG	Level-1-260C-UNLIM	
TPS62050DGSG4	ACTIVE	MSOP	DGS	10	80	Green (RoHS & no Sb/Br)	CU NIPDAUAG	Level-1-260C-UNLIM	
TPS62050DGSR	ACTIVE	MSOP	DGS	10	2500	Green (RoHS & no Sb/Br)	CU NIPDAUAG	Level-1-260C-UNLIM	
TPS62050DGSRG4	ACTIVE	MSOP	DGS	10	2500	Green (RoHS & no Sb/Br)	CU NIPDAUAG	Level-1-260C-UNLIM	
TPS62051DGS	ACTIVE	MSOP	DGS	10	80	Green (RoHS & no Sb/Br)	CU NIPDAU	Level-1-260C-UNLIM	
TPS62051DGSG4	ACTIVE	MSOP	DGS	10	80	Green (RoHS & no Sb/Br)	CU NIPDAU	Level-1-260C-UNLIM	
TPS62051DGSR	ACTIVE	MSOP	DGS	10	2500	Green (RoHS & no Sb/Br)	CU NIPDAU	Level-1-260C-UNLIM	
TPS62051DGSRG4	ACTIVE	MSOP	DGS	10	2500	Green (RoHS & no Sb/Br)	CU NIPDAU	Level-1-260C-UNLIM	
TPS62052DGS	ACTIVE	MSOP	DGS	10	80	Green (RoHS & no Sb/Br)	CU NIPDAU	Level-1-260C-UNLIM	
TPS62052DGSG4	ACTIVE	MSOP	DGS	10	80	Green (RoHS & no Sb/Br)	CU NIPDAU	Level-1-260C-UNLIM	
TPS62052DGSR	ACTIVE	MSOP	DGS	10	2500	Green (RoHS & no Sb/Br)	CU NIPDAU	Level-1-260C-UNLIM	
TPS62052DGSRG4	ACTIVE	MSOP	DGS	10	2500	Green (RoHS & no Sb/Br)	CU NIPDAU	Level-1-260C-UNLIM	
TPS62054DGS	ACTIVE	MSOP	DGS	10	80	Green (RoHS & no Sb/Br)	CU NIPDAU	Level-1-260C-UNLIM	
TPS62054DGSG4	ACTIVE	MSOP	DGS	10	80	Green (RoHS & no Sb/Br)	CU NIPDAU	Level-1-260C-UNLIM	
TPS62054DGSR	ACTIVE	MSOP	DGS	10	2500	Green (RoHS & no Sb/Br)	CU NIPDAU	Level-1-260C-UNLIM	
TPS62054DGSRG4	ACTIVE	MSOP	DGS	10	2500	Green (RoHS & no Sb/Br)	CU NIPDAU	Level-1-260C-UNLIM	
TPS62056DGS	ACTIVE	MSOP	DGS	10	80	Green (RoHS & no Sb/Br)	CU NIPDAU	Level-1-260C-UNLIM	

Orderable Device	Status <sup>(1)</sup>	Package Type	Package Drawing	Pins	Package Qty	Eco Plan <sup>(2)</sup>	Lead/ Ball Finish	MSL Peak Temp <sup>(3)</sup>	Samples (Requires Login)
TPS62056DGSG4	ACTIVE	MSOP	DGS	10	80	Green (RoHS & no Sb/Br)	CU NIPDAU	Level-1-260C-UNLIM	
TPS62056DGSR	ACTIVE	MSOP	DGS	10	2500	Green (RoHS & no Sb/Br)	CU NIPDAU	Level-1-260C-UNLIM	
TPS62056DGSRG4	ACTIVE	MSOP	DGS	10	2500	Green (RoHS & no Sb/Br)	CU NIPDAU	Level-1-260C-UNLIM	

<sup>(1)</sup> The marketing status values are defined as follows:

**ACTIVE:** Product device recommended for new designs.

**LIFEBUY:** TI has announced that the device will be discontinued, and a lifetime-buy period is in effect.

**NRND:** Not recommended for new designs. Device is in production to support existing customers, but TI does not recommend using this part in a new design.

**PREVIEW:** Device has been announced but is not in production. Samples may or may not be available.

**OBSOLETE:** TI has discontinued the production of the device.

<sup>(2)</sup> Eco Plan - The planned eco-friendly classification: Pb-Free (RoHS), Pb-Free (RoHS Exempt), or Green (RoHS & no Sb/Br) - please check <http://www.ti.com/productcontent> for the latest availability information and additional product content details.

**TBD:** The Pb-Free/Green conversion plan has not been defined.

**Pb-Free (RoHS):** TI's terms "Lead-Free" or "Pb-Free" mean semiconductor products that are compatible with the current RoHS requirements for all 6 substances, including the requirement that lead not exceed 0.1% by weight in homogeneous materials. Where designed to be soldered at high temperatures, TI Pb-Free products are suitable for use in specified lead-free processes.

**Pb-Free (RoHS Exempt):** This component has a RoHS exemption for either 1) lead-based flip-chip solder bumps used between the die and package, or 2) lead-based die adhesive used between the die and leadframe. The component is otherwise considered Pb-Free (RoHS compatible) as defined above.

**Green (RoHS & no Sb/Br):** TI defines "Green" to mean Pb-Free (RoHS compatible), and free of Bromine (Br) and Antimony (Sb) based flame retardants (Br or Sb do not exceed 0.1% by weight in homogeneous material)

<sup>(3)</sup> MSL, Peak Temp. -- The Moisture Sensitivity Level rating according to the JEDEC industry standard classifications, and peak solder temperature.

**Important Information and Disclaimer:** The information provided on this page represents TI's knowledge and belief as of the date that it is provided. TI bases its knowledge and belief on information provided by third parties, and makes no representation or warranty as to the accuracy of such information. Efforts are underway to better integrate information from third parties. TI has taken and continues to take reasonable steps to provide representative and accurate information but may not have conducted destructive testing or chemical analysis on incoming materials and chemicals. TI and TI suppliers consider certain information to be proprietary, and thus CAS numbers and other limited information may not be available for release.

In no event shall TI's liability arising out of such information exceed the total purchase price of the TI part(s) at issue in this document sold by TI to Customer on an annual basis.

**TAPE AND REEL INFORMATION**
**REEL DIMENSIONS**

**TAPE DIMENSIONS**

A0	Dimension designed to accommodate the component width
B0	Dimension designed to accommodate the component length
K0	Dimension designed to accommodate the component thickness
W	Overall width of the carrier tape
P1	Pitch between successive cavity centers

**TAPE AND REEL INFORMATION**

\*All dimensions are nominal

Device	Package Type	Package Drawing	Pins	SPQ	Reel Diameter (mm)	Reel Width W1 (mm)	A0 (mm)	B0 (mm)	K0 (mm)	P1 (mm)	W (mm)	Pin1 Quadrant
TPS62050DGSR	MSOP	DGS	10	2500	330.0	12.4	5.3	3.4	1.4	8.0	12.0	Q1
TPS62051DGSR	MSOP	DGS	10	2500	330.0	12.4	5.3	3.4	1.4	8.0	12.0	Q1
TPS62052DGSR	MSOP	DGS	10	2500	330.0	12.4	5.3	3.4	1.4	8.0	12.0	Q1
TPS62054DGSR	MSOP	DGS	10	2500	330.0	12.4	5.3	3.4	1.4	8.0	12.0	Q1
TPS62056DGSR	MSOP	DGS	10	2500	330.0	12.4	5.3	3.4	1.4	8.0	12.0	Q1

**TAPE AND REEL BOX DIMENSIONS**

\*All dimensions are nominal

Device	Package Type	Package Drawing	Pins	SPQ	Length (mm)	Width (mm)	Height (mm)
TPS62050DGSR	MSOP	DGS	10	2500	367.0	367.0	35.0
TPS62051DGSR	MSOP	DGS	10	2500	367.0	367.0	35.0
TPS62052DGSR	MSOP	DGS	10	2500	367.0	367.0	35.0
TPS62054DGSR	MSOP	DGS	10	2500	367.0	367.0	35.0
TPS62056DGSR	MSOP	DGS	10	2500	367.0	367.0	35.0

DGS (S-PDSO-G10)

PLASTIC SMALL-OUTLINE PACKAGE



- NOTES:
- A. All linear dimensions are in millimeters.
  - B. This drawing is subject to change without notice.
  - C. Body dimensions do not include mold flash or protrusion.
  - D. Falls within JEDEC MO-187 variation BA.



## IMPORTANT NOTICE

Texas Instruments Incorporated and its subsidiaries (TI) reserve the right to make corrections, enhancements, improvements and other changes to its semiconductor products and services per JESD46C and to discontinue any product or service per JESD48B. Buyers should obtain the latest relevant information before placing orders and should verify that such information is current and complete. All semiconductor products (also referred to herein as "components") are sold subject to TI's terms and conditions of sale supplied at the time of order acknowledgment.

TI warrants performance of its components to the specifications applicable at the time of sale, in accordance with the warranty in TI's terms and conditions of sale of semiconductor products. Testing and other quality control techniques are used to the extent TI deems necessary to support this warranty. Except where mandated by applicable law, testing of all parameters of each component is not necessarily performed.

TI assumes no liability for applications assistance or the design of Buyers' products. Buyers are responsible for their products and applications using TI components. To minimize the risks associated with Buyers' products and applications, Buyers should provide adequate design and operating safeguards.

TI does not warrant or represent that any license, either express or implied, is granted under any patent right, copyright, mask work right, or other intellectual property right relating to any combination, machine, or process in which TI components or services are used. Information published by TI regarding third-party products or services does not constitute a license to use such products or services or a warranty or endorsement thereof. Use of such information may require a license from a third party under the patents or other intellectual property of the third party, or a license from TI under the patents or other intellectual property of TI.

Reproduction of significant portions of TI information in TI data books or data sheets is permissible only if reproduction is without alteration and is accompanied by all associated warranties, conditions, limitations, and notices. TI is not responsible or liable for such altered documentation. Information of third parties may be subject to additional restrictions.

Resale of TI components or services with statements different from or beyond the parameters stated by TI for that component or service voids all express and any implied warranties for the associated TI component or service and is an unfair and deceptive business practice. TI is not responsible or liable for any such statements.

Buyer acknowledges and agrees that it is solely responsible for compliance with all legal, regulatory and safety-related requirements concerning its products, and any use of TI components in its applications, notwithstanding any applications-related information or support that may be provided by TI. Buyer represents and agrees that it has all the necessary expertise to create and implement safeguards which anticipate dangerous consequences of failures, monitor failures and their consequences, lessen the likelihood of failures that might cause harm and take appropriate remedial actions. Buyer will fully indemnify TI and its representatives against any damages arising out of the use of any TI components in safety-critical applications.

In some cases, TI components may be promoted specifically to facilitate safety-related applications. With such components, TI's goal is to help enable customers to design and create their own end-product solutions that meet applicable functional safety standards and requirements. Nonetheless, such components are subject to these terms.

No TI components are authorized for use in FDA Class III (or similar life-critical medical equipment) unless authorized officers of the parties have executed a special agreement specifically governing such use.

Only those TI components which TI has specifically designated as military grade or "enhanced plastic" are designed and intended for use in military/aerospace applications or environments. Buyer acknowledges and agrees that any military or aerospace use of TI components which have **not** been so designated is solely at the Buyer's risk, and that Buyer is solely responsible for compliance with all legal and regulatory requirements in connection with such use.

TI has specifically designated certain components which meet ISO/TS16949 requirements, mainly for automotive use. Components which have not been so designated are neither designed nor intended for automotive use; and TI will not be responsible for any failure of such components to meet such requirements.

### Products

Audio	<a href="http://www.ti.com/audio">www.ti.com/audio</a>
Amplifiers	<a href="http://amplifier.ti.com">amplifier.ti.com</a>
Data Converters	<a href="http://dataconverter.ti.com">dataconverter.ti.com</a>
DLP® Products	<a href="http://www.dlp.com">www.dlp.com</a>
DSP	<a href="http://dsp.ti.com">dsp.ti.com</a>
Clocks and Timers	<a href="http://www.ti.com/clocks">www.ti.com/clocks</a>
Interface	<a href="http://interface.ti.com">interface.ti.com</a>
Logic	<a href="http://logic.ti.com">logic.ti.com</a>
Power Mgmt	<a href="http://power.ti.com">power.ti.com</a>
Microcontrollers	<a href="http://microcontroller.ti.com">microcontroller.ti.com</a>
RFID	<a href="http://www.ti-rfid.com">www.ti-rfid.com</a>
OMAP Mobile Processors	<a href="http://www.ti.com/omap">www.ti.com/omap</a>
Wireless Connectivity	<a href="http://www.ti.com/wirelessconnectivity">www.ti.com/wirelessconnectivity</a>

### Applications

Automotive and Transportation	<a href="http://www.ti.com/automotive">www.ti.com/automotive</a>
Communications and Telecom	<a href="http://www.ti.com/communications">www.ti.com/communications</a>
Computers and Peripherals	<a href="http://www.ti.com/computers">www.ti.com/computers</a>
Consumer Electronics	<a href="http://www.ti.com/consumer-apps">www.ti.com/consumer-apps</a>
Energy and Lighting	<a href="http://www.ti.com/energy">www.ti.com/energy</a>
Industrial	<a href="http://www.ti.com/industrial">www.ti.com/industrial</a>
Medical	<a href="http://www.ti.com/medical">www.ti.com/medical</a>
Security	<a href="http://www.ti.com/security">www.ti.com/security</a>
Space, Avionics and Defense	<a href="http://www.ti.com/space-avionics-defense">www.ti.com/space-avionics-defense</a>
Video and Imaging	<a href="http://www.ti.com/video">www.ti.com/video</a>

**TI E2E Community** [e2e.ti.com](http://e2e.ti.com)